

# HINO 338

**4 x 2 CONVENTIONAL**

**GVW: 33,000 lbs.**

**BBC: 108"**

**Engine Model: J08E-TW (Turbo Intercooled)**

**2009 SPECIFICATIONS**

DIMENSIONS (On standard specification)									
Wheelbase/Code	A in.	152.0/G	175.0/J	187.0/L	205.0/M	217.0/P	235.0/R	253.0/T	271.0/V
Overall length	B in.	242.6	278.6	302.6	320.6	354.6	372.6	390.6	390.6
Overall width	C in.	96.5	96.5	96.5	96.5	96.5	96.5	96.5	96.5
Overall height	D in.	106.9	106.9	106.9	106.9	106.9	106.9	106.9	106.9
Cab to axle	E in.	84.6	107.6	119.6	137.6	149.6	167.6	185.6	203.6
Rear overhang	F in.	50.0	63.0	75.0	75.0	97.0	97.0	97.0	79.0
Frame height at:	G in.	36.8	36.8	36.8	36.8	36.8	36.8	36.8	36.8
	H in.	40.6	40.6	40.6	40.6	40.6	40.6	40.6	40.6
Road clearance (at diff. axle)	J in.	11.2	11.2	11.2	11.2	11.2	11.2	11.2	11.2
Tread:	K in.	79.3	79.3	79.3	79.3	79.3	79.3	79.3	79.3
	L in.	72.2	72.2	72.2	72.2	72.2	72.2	72.2	72.2
Turning radius:	ft.	42.0	47.5	50.4	54.8	57.7	62.1	66.4	70.8
	ft.	45.4	50.9	53.8	58.2	61.1	65.5	69.8	74.2

CHASSIS WEIGHTS (On standard specification)										
MT	Total weight	lb.	10,070	10,200	10,280	10,410	10,540	10,630	10,680	10,740
	Front axle	lb.	6,170	6,265	6,310	6,430	6,450	6,530	6,590	6,705
	Rear axle	lb.	3,900	3,935	3,970	3,980	4,090	4,100	4,090	4,035
AT	Total weight	lb.	10,310	10,430	10,500	10,640	10,770	10,860	10,900	10,970
	Front axle	lb.	6,330	6,440	6,475	6,605	6,625	6,715	6,775	6,890
	Rear axle	lb.	3,980	3,990	4,025	4,035	4,145	4,145	4,125	4,080

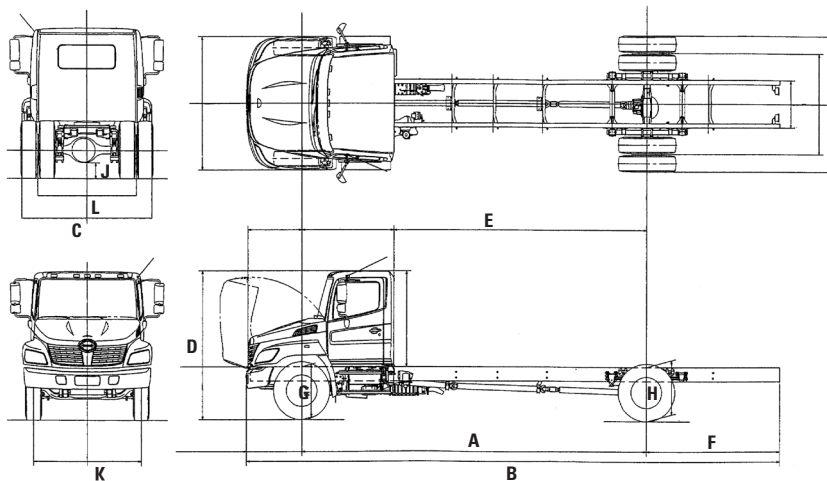

ENGINE	
Model	HINO J08E-TW
Type	Diesel 4-cy., 6-cyl. in-line, water-cooled
Combustion system	Direct injection type
Max. output (SAE Gross)	260HP at 2,500 rpm
Max. torque (SAE Gross)	585 lb.-ft. at 1,500 rpm
Bore and stroke	4.41 x 5.12 in.
Piston displacement	7.680L
Fuel injection pump	Radial plunger pump (HP-4)
Governor	Electronically controlled
Intake system	Turbocharged and intercooled
Air cleaner	Paper filter type (Donaldson)
Air compressor type	Single cylinder, water-cooled
Fan clutch	Bimetal thermostat sensor regulates fan speed
Glow plugs	Standard
Air compressor	Single cylinder, 10.0 cfm @ 1,250 rpm

POWERTRAIN AND PERFORMANCE					
33,000 lbs. GVW and 11.00R22.5-14 tires					
Powertrain	<input type="checkbox"/> STD.	<input type="checkbox"/> OPT.	<input type="checkbox"/> OPT.	<input type="checkbox"/> OPT.	<input type="checkbox"/> OPT.
Max. speed mph	75*	77*	76*	80*	76*
Startability (tan.θ) %	38.2	37.2	49.3	47.2	50.0
Transmission Model	Eaton FS6406A	Allison 3000RDS	Allison 3000RDS		
	Type	Six-speed Direct drive synchronesh 1st-6th	Six-speed automatic	Six-speed automatic	
Ratios	1st.	9.008	3.487	3.487	
	2nd.	5.270	1.864	1.864	
	3rd.	3.220	1.409	1.409	
	4th.	2.040	1.000	1.000	
	5th.	1.361	0.750	0.750	
	6th.	1.000	0.650	0.650	
	Rev.	8.625	5.027	5.027	
Rear axle gear ratios	RS21-145	4.110	3.900	5.570	
	RS23-160				5.380 5.630
Tire is combined with ratio	11R22.5-14	295/75R22.5	11R22.5-14	11R22.5-14	11R22.5-14

(\* Maximum speed is limited with speed limiter)

**ROADSIDE ASSISTANCE**

HinoWatch, service free of charge. 3-year unlimited roadside assistance includes: lockout, out of fuel, battery jumpstart, information and warranty towing.



# HINO 338

**4 x 2 CONVENTIONAL**  
**GVW:** 33,000 lbs.  
**BBC:** 108"  
**Engine Model:** J08E-TW (Turbo Intercooled)

**SPEC NO.** SS-NV027  
**FORM NO.** HSS338 0708

## WEIGHT CAPACITIES

Front axle	lbs.	12,000
Rear axle	lbs.	21,000
Front spring	lbs.	12,000
Rear spring	lbs.	21,000

## LIQUID CAPACITIES

Fuel tank	gal.	52
Cooling system	gal.	6.21 : Eaton FS6406A 6.08 : Allison 3000RDS
Engine oil	qt.	16.15

## AXLE/SUSPENSION

Front axle	MFS-12 series reversed Elliot, "I" beam with 12,000 lb (oil lubricated type)
Front spring	Taper-leaf springs shock absorbers
Rear axle	RS21-145 series Full-floating, single reduction Single-speed by hypoid gearings
Rear spring	Semi-elliptic main and auxiliary helper-leaf spring

## FRAME

Ladder type		Straight C Channel
Width	in.	34 : W/B = 175-235 34.1 : W/B = 253
Yield strength	PSI	80,000
Resisting bending moment (one side)	in.-lbs.	1,280,800 no reinforcement

## STEERING

Steering column	Tilt and telescopic with lock adjustability
Steering system	TRW recirculating ball, with hydraulic booster, integral type

## CLUTCH

Type	Dry single plate with damper springs Eaton-Spicer SAS 1401 series
Facing material	Ceramic
Facing outside (in.)	13.8
Control	Hydraulic

## WHEELS/TIRES

6 Wheels	22.5 x 8.25 10-stud disc.
Wheel style	Steel, powder coated
6 Tires	11R22.5(G)
Tire brand and pattern	Bridgestone Fr-rib/Rr-rug type

## BRAKES

Service brake	Full air, dual circuit, "S" cam type, leading and trailing shoes, with automatic adjustment
Disc diameter x lining width x thickness (in.)	Front; 15 x 4 x 0.73 Rear; 16.5 x 7 x 0.85
Control	Full air dual circuit with Antilock Brake System(ABS)
Parking brake	Spring brake acting on rear wheels
Air dryer for air tank	Equipped
Exhaust brake	Electric-pneumatic with valve in exhaust pipe

## NOTE:

All specifications of the products are with normal manufacturing allowances and tolerances. HINO MOTORS SALES U.S.A., INC. reserves the right to alter specifications at any time without previous notice. Some optional items of equipment may require extra time due to the need for their adaptation on the product line.

## CAB EQUIPMENT

Air conditioning	Standard
Cab construction	All steel welded
Seating	Three
Driver's seat	Adjustable reclining, covered with vinyl with air suspension
Passenger's seat	Bench type, covered with vinyl
Seat belts	3-point type (driver and passenger), one 2-point type (center)
Heater/Defroster	18,357 BTU/h
Mirrors outside rearview	Four, 1-flat and 1-convex at each side
Sun visors	Two
Over-head consoles	Two
Ventilator	Electric forced air
Windshield	Laminated
Windshield wipers	Dual electric, 2-speed and intermittent
Cup holders	Two at center cluster (Single) - for MT, (Dual) - for AT
Cigarette lighter	Equipped
Speakers	Two for front
Coat hook	One (rear panel)
Door pockets	Two
Cruise control	Standard

## DASH INSTRUMENTATION

Meters and gauges ft. lb. system
Speedometer-mph (km/h)
Odometer (mile)
Fuel gauge
Coolant temperature gauge
Engine tachometer
Warning and pilot lamps and buzzers
Oil pressure warning lamp and buzzer
Brake pressure warning lamp and buzzer
Coolant level warning lamp and buzzer
Battery charging warning lamp
High beam indicator lamp
Turn signal pilot lamp
Parking brake warning lamp
Engine control system warning lamp
ABS warning lamp
Driver Information Display
Instant and trip fuel consumption
DPR monitor
Maintenance schedule
Engine/vehicle diagnostics

## ELECTRICAL EQUIPMENT

Batteries	Two, parallel connection, each 12V
Capacity	1200 CCA
Alternator	12 V, 100 A, brush Delco
Starter	12 V, 4.8 kW Denso
Engine shutdown system	Equipped
Speed limiter	Equipped
Car audio	AM/FM radio with CD
Headlamps	Daylight running - integrated with turn signal and hazard lamps
Identification lamps (front)	
Stop/Tail lamps	
Back-up lamps	
Front side marker lamps	
Trucklite LED cab marker lamps (front)	
Electric horn (dual)	

## CHASSIS EQUIPMENT

Radiator grille	Chrome
Fuel tank	Aluminum
Fuel pre-filter	Heated pre-filter (dust) and sedimenter (water)
Reflectors	Two rear, two front side
Tow hook	One at front
Air dryer	NABCO, heated
Air tank	49L

## CAB CONFIGURATION OPTIONS

Extended cab	30" cab extension, available with full-width bench seat or 26" day bunk
Right hand drive, dual-steer, sit down	Driver controls mounted on both sides of cab
Right hand drive, dual-steer, stand-up	Driver controls mounted on both sides of cab, right hand side of cab designed for operation while standing with easy entry / exit

## OPTIONAL EQUIPMENT

Air horn
Air ride suspension - Hendrickson (N/A on G, J wheelbases)
Air ride suspension dump valve - Electric
Alternator - 12 V, 105 A, brushless
Battery - Three parallel connection each 12 V (GR27x3)
Battery - Two or three parallel connection each 12 V (GR31 type)
Battery - Absorbed glass mat (AGM) 31 Configuration
Bumper, front - Black and 4 inch extension (available 3 piece)
Bumper, front - White and 4 inch extension (available 3 piece)
Bumper, front - White 3 piece (available with one or two tow hooks)
Bumper, front - Chrome and 4 inch extension
Bumper, front - Chrome (available with one or two tow hooks)
Cab paint, exterior - Black or red
Cold weather package <ul style="list-style-type: none"> <li>- Heated mirrors (available in chrome)</li> <li>- Engine block heater</li> <li>- Bendix air dryer</li> </ul>
Clutch - Eaton 1401 self-adjusting solo
Clutch - Eaton 1402 twin plate self-adjusting solo
Differential lock with controls
Engine block heater
Exhaust system - Vertical stack type (N/A with 95 gal. fuel tank)
Frame rail - 120,000 PSI
Fuel tank - Dual 52 gal. (N/A on G wheelbase)
Fuel tank - Single 95 gal.
Mirrors, outside rearview - Heated with marker light
Mirrors, outside rearview - Chrome, heated with marker light
Mirrors, outside rearview - Chrome
Power windows and power door locks
Seats - Vinyl with reclining single person passenger seat
Seats - Fabric with reclining single person passenger seat
Seats - Fabric with two person bench seat
Shock absorbers, rear
Stabilizer, rear
Stabilizer, rear - With shock absorbers
Synthetic fluids - Auto/manual transmission and rear differential
Tire pattern - Rib on rear
Tire size - 295/75R22.5-14(G) Bridgestone
Tow hooks - Two at front
Transmission, automatic - Allison 3000 RDS (rear axle ratio 5.57)
Transmission, automatic - Eaton Ultrashift Highway Value
Wheels - Alcoa polished aluminum (inner rear wheels are steel)
Engine idle throttle knob - Removed
Exhaust brake - Disengage