

HINO 268A

4 x 2 CONVENTIONAL

GVW: 25,950 lbs.

BBC: 108"

Engine Model: J08E-TV (Turbo Intercooled)

2009 SPECIFICATIONS

DIMENSIONS (On standard specification)									
Wheelbase/Code	A in.	152.0/G	175.0/J	187.0/L	205.0/M	217.0/P	235.0/R	253.0/T	271.0/V
Overall length	B in.	242.6	278.6	302.6	320.6	354.6	372.6	390.6	390.6
Overall width	C in.	96.5	96.5	96.5	96.5	96.5	96.5	96.5	96.5
Overall height	D in.	106.9	106.9	106.9	106.9	106.9	106.9	106.9	106.9
Cab to axle	E in.	84.6	107.6	119.6	137.6	149.6	167.6	185.6	203.6
Rear overhang	F in.	50.0	63.0	75.0	75.0	97.0	97.0	97.0	79.0
Frame height at:	G in.	37.0	37.0	37.0	37.0	37.0	37.0	37.0	37.0
	H in.	39.8	39.8	39.8	39.8	39.8	39.8	39.8	39.8
Road clearance (at diff. axle)	J in.	11.2	11.2	11.2	11.2	11.2	11.2	11.2	11.2
Tread:	K in.	79.3	79.3	79.3	79.3	79.3	79.3	79.3	79.3
	L in.	72.2	72.2	72.2	72.2	72.2	72.2	72.2	72.2
Turning radius:	ft.	57.6	62.0	66.4	70.8	57.6	62.0	66.4	70.8
	ft.	61.0	65.4	69.8	74.2	61.0	65.4	69.8	74.2

CHASSIS WEIGHTS (On standard specification)										
MT	Total weight	lb.	10,000	9,950	10,020	10,130	10,240	10,310	10,350	10,390
	Front axle	lb.	6,165	6,180	6,230	6,325	6,350	6,430	6,480	6,565
	Rear axle	lb.	3,835	3,770	3,790	3,805	3,890	3,880	3,870	3,825
AT	Total weight	lb.	9,940	9,900	9,960	10,070	10,190	10,260	10,300	10,340
	Front axle	lb.	6,105	6,130	6,170	6,265	6,300	6,380	6,430	6,515
	Rear axle	lb.	3,835	3,770	3,790	3,805	3,890	3,880	3,870	3,825

ENGINE	
Model	HINO J08E-TV
Type	Diesel 4-cy., 6-cyl. in-line, water-cooled
Combustion system	Direct injection type
Max. output (SAE Gross)	220HP at 2,500 rpm
Max. torque (SAE Gross)	520 lb.-ft. at 1,500 rpm
Bore and stroke	4.41 x 5.12 in.
Piston displacement	7.680L
Fuel injection pump	Radial plunger pump (HP-4)
Governor	Electronically controlled
Intake system	Turbocharged and intercooled
Air cleaner	Paper filter type (Donaldson)
Fan clutch	Bimetal thermostat sensor regulates fan speed
Glow plugs	Standard
Air compressor	Single cylinder, 10.0 cfm @ 1,250 rpm

POWERTRAIN AND PERFORMANCE				
25,950 lbs. GVW				
Powertrain	<input type="checkbox"/> STD.	<input type="checkbox"/> OPT.	<input type="checkbox"/> STD.	<input type="checkbox"/> OPT.
Max. speed mph	75	77	77*	78*
Startability (tan.θ) %	44.2	42.6	34.3	33.7
Transmission Model	Eaton FS5406A	Allison 2200HS/RDS	Allison 2500RDS	
	Type	Six-speed direct drive synchromesh 1st-6th	Six-speed automatic	Six-speed automatic
Ratios	1st.	9.008	3.102	3.512
	2nd.	5.270	1.811	1.892
	3rd.	3.220	1.406	1.439
	4th.	2.040	1.000	1.000
	5th.	1.361	0.712	0.737
	6th.	1.000	0.610	0.640
	Rev.	8.625	4.492	5.086
Rear axle gear ratios	4.110	3.730	5.570	5.130
Tire is combined with ratio	11R22.5-14	255/80R22.5	11R22.5-14	255/80R22.5

(*) Maximum speed is limited with speed limiter

ROADSIDE ASSISTANCE
HinoWatch, service free of charge. 3-year unlimited roadside assistance includes: lockout, out of fuel, battery jumpstart, information and warranty towing.

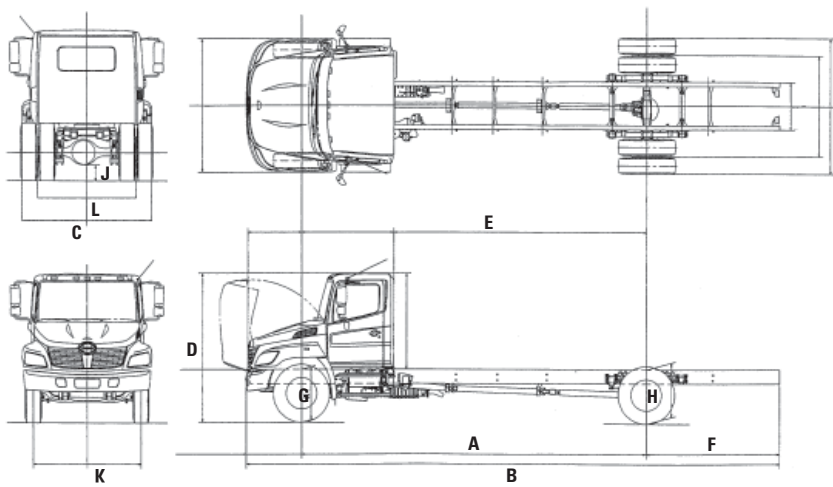

WEIGHT CAPACITIES

Front axle	lbs.	10,000
Rear axle	lbs.	19,000
Front spring	lbs.	12,000
Rear spring	lbs.	21,000

LIQUID CAPACITIES

Fuel tank	gal.	52
Cooling system	gal.	6.21 : Eaton FS5406A 6.08 : Allison 2200HS
Engine oil	qt.	16.15

AXLE/SUSPENSION

Front axle	MFS-10 series reversed Elliot, "I" beam with 12,000 lb (oil lubricated type)
Front spring	Taper-leaf springs shock absorbers
Rear axle	RS19-145 series Full-floating, single reduction Single-speed by hypoid gearings with oil lubricated type
Rear spring	Semi-elliptic main and auxiliary helper-leaf spring

FRAME

Ladder type		Straight C Channel
Width	in.	34
Yield strength	PSI	80,000
Resisting bending moment (one side)	in.-lbs.	1,031,900 no reinforcement

STEERING

Steering column	Tilt and telescopic with lock adjustability
Steering system	TRW recirculating ball, with hydraulic booster, integral type

CLUTCH

Type	Dry single plate with damper springs EATON-SPICER SAS 1401 series
Facing material	Ceramic
Facing outside (in.)	13.8
Control	Hydraulic

BRAKES

Service brake	Full air, dual circuit, "S" cam type, leading and trailing shoes, with automatic adjustment
Disc diameter x lining width x thickness (in.)	Front; 15 x 4 x 0.73 Rear; 16.5 x 7 x 0.85
Control	Full air dual circuit with Antilock Brake System (ABS)
Parking brake	Spring brake on rear wheels
Air dryer for air tank	Equipped
Exhaust brake	Electric-pneumatic with valve in exhaust pipe

CHASSIS EQUIPMENT

Radiator grille	Chrome
Fuel tank	Aluminum
Fuel pre-filter	Heated pre-filter (dust) and sediment (water)
Reflectors	Two rear, two front side
Tow hook	One at front
Air dryer	NABCO, heated
Air tank	49L

CAB EQUIPMENT

Air conditioning	Standard
Cab construction	All steel welded
Seating	Three
Driver's seat	Adjustable reclining, covered with vinyl with air suspension
Passenger's seat	Bench type, covered with vinyl
Seat belts	3-point type (driver and passenger), one 2-point type (center)
Heater/Defroster	18,357 BTU/h
Mirrors, outside rearview	Four, 1-flat and 1-convex at each side
Sun visors	Two
Over-head consoles	Two
Ventilator	Electric forced air
Windshield	Laminated
Windshield wipers	Dual electric, 2-speed and intermittent
Cup holder	Two at center cluster (Single) - for MT, (Dual) - for AT
Cigarette lighter	Equipped
Speakers	Two for front
Coat hook	One (rear panel)
Door pockets	Two
Cruise control	Standard

DASH INSTRUMENTATION

Meters and gauges	ft. lb. system
	Speedometer-mph (km/h)
	Odometer (mile)
	Fuel gauge
	Coolant temperature gauge
	Engine tachometer
	Air pressure gauge
Warning and pilot lamps and buzzers	
	Oil pressure warning lamp and buzzer
	Air pressure warning lamp and buzzer
	Coolant level warning lamp and buzzer
	Battery charging warning lamp
	High beam indicator lamp
	Turn signal pilot lamp
	Parking brake warning lamp
	Engine control system warning lamp
	ABS warning lamp
Driver Information Display	
	Instant and trip fuel consumption
	DPR monitor
	Maintenance schedule
	Engine/vehicle diagnostics

ELECTRICAL EQUIPMENT

Batteries	Two, parallel connection, each 12V
Capacity	1200 CCA
Alternator	12 V, 100 A, brush Delco
Starter	12 V, 4.0 kW Denso
Car audio	AM/FM radio with CD
Headlamps	Daylight running - integrated with turn signal and hazard lamps
Identification lamps (front)	
Stop/Tail lamps	
Back-up lamps	
Side-flasher lamp	
Front side marker lamps	
Trucklite LED cab marker lamps (front)	
Electrical horn (dual)	

WHEELS/TIRES

6 Wheels	22.5 x 8.25 10-stud disc.
Wheel style	Steel, powder coated
6 Tires	11R22.5(G)
Tire brand and pattern	Bridgestone Fr-rib/Rr-lug type

CAB CONFIGURATION OPTIONS

Extended cab	30" cab extension, available with full-width bench seat or 26" day bunk
Right hand drive, dual-steer, sit down	Driver controls mounted on both sides of cab
Right hand drive, dual-steer, stand-up	Driver controls mounted on both sides of cab, right hand side of cab designed for operation while standing with easy entry / exit

OPTIONAL EQUIPMENT

Air horn	
Air ride suspension - Hendrickson	(N/A on G, J wheelbases)
Air ride suspension dump valve	- Electric
Alternator	- 12 V, 105 A, brushless
Battery	- Three parallel connection each 12 V (GR27x3)
Battery	- Two or three parallel connection each 12 V (GR31 type)
Battery	- Absorbed glass mat (AGM) 31 Configuration
Bumper, front	- Black and 4 inch extension (available 3 piece)
Bumper, front	- White and 4 inch extension (available 3 piece)
Bumper, front	- White 3 piece (available with one or two tow hooks)
Bumper, front	- Chrome and 4 inch extension
Bumper, front	- Chrome (available with one or two tow hooks)
Cab paint, exterior	- Black or red
Cold weather package	- Heated mirrors (available in chrome) - Engine block heater - Bendix air dryer
Clutch	- Eaton 1401 self-adjusting solo
Clutch	- Eaton 1402 twin plate self-adjusting solo
Differential lock with controls	
Engine block heater	
Exhaust system	- Vertical stack type (N/A with 95 gal. fuel tank)
Fuel tank	- Dual 52 gal. (N/A on G wheelbase)
Fuel tank	- Single 95 gal.
Mirrors, outside rearview	- Heated with marker light
Mirrors, outside rearview	- Chrome, heated with marker light
Mirrors, outside rearview	- Chrome
Power windows and power door locks	
Seats	- Vinyl with reclining single person passenger seat
Seats	- Fabric with reclining single person passenger seat
Seats	- Fabric with two person bench seat
Shock absorbers, rear	
Stabilizer, rear	
Stabilizer, rear	- With shock absorbers
Synthetic fluids	- Auto/manual transmission and rear differential
Tire pattern	- Rib on rear
Tire size	- 255/80R22.5-14(G) Michelin
Tire size	- 255/70R22.5-16(H) Bridgestone
Tire size	- 295/75R22.5-14(G) Bridgestone
Transmission, automatic	- Allison 2200 HS (rear axle ratio 5.57)
Transmission, automatic	- Allison 2200 RDS (rear axle ratio 5.13)
Transmission, automatic	- Allison 2500 RDS (rear axle ratio 5.57)
Transmission, automatic	- Eaton Ultrashift Highway Value
Wheels	- Alcoa polished aluminum (inner rear wheels are steel)
Engine idle throttle knob	- Removed
Exhaust brake	- Disengage

NOTE:

All specifications of the products are with normal manufacturing allowances and tolerances. HINO MOTORS SALES U.S.A., INC. reserves the right to alter specifications at any time without previous notice. Some optional items of equipment may require extra time due to the need for their adaptation on the product line.