

2012 HINO 258LP

4 x 2 CONVENTIONAL GVW: 25,500 LBS. BBC: 108" ENGINE MODEL: J08E-VC (TURBO INTERCOOLED)



A Toyota Group Company



DIMENSIONS

Wheelbase	A in.	152/G	175/J	187/L	205/M	212/N	217/P	235/R	253/T	271/V
Overall length	B in.	242.6	278.6	302.6	320.6	354.6	354.6	372.6	390.6	390.6
Overall width	C in.	95.7	95.7	95.7	95.7	95.7	95.7	95.7	95.7	95.7
Overall height	D in.	102.8	102.8	102.8	102.8	102.8	102.8	102.8	102.8	102.8
Cab to axle	E in.	84.6	107.6	119.6	137.6	144.6	149.6	167.6	185.6	203.6
Rear overhang	F in.	50.0	63.0	75.0	75.0	102.0	97.0	97.0	97.0	79.0
Frame height at										
Front axle	G in.	32.7	32.7	32.7	32.7	32.7	32.7	32.7	32.7	32.7
Rear axle	H in.	35.8	35.8	35.8	35.8	35.8	35.8	35.8	35.8	35.8
Road clearance (at diff. axle)	J in.	7.1	7.1	7.1	7.1	7.1	7.1	7.1	7.1	7.1
Tread										
Front	K in.	79.5	79.5	79.5	79.5	79.5	79.5	79.5	79.5	79.5
Rear	L in.	72.4	72.4	72.4	72.4	72.4	72.4	72.4	72.4	72.4
Turning radius										
Curb to Curb	ft.	42.4	48.0	50.9	55.3	57.0	58.3	62.7	67.1	71.5
Wall to Wall	ft.	45.7	51.4	54.3	58.7	60.4	61.6	66.0	70.4	74.9

CHASSIS WEIGHTS (On standard specification, without spare tire & standard tool set)

AT	Total weight	lb.	9,480	9,420	9,490	9,590	9,700	9,710	9,770	9,800	9,840
	Front axle	lb.	5,810	5,970	6,030	6,140	6,195	6,170	6,255	6,315	6,410
	Rear axle	lb.	3,670	3,450	3,460	3,450	3,505	3,540	3,515	3,485	3,430

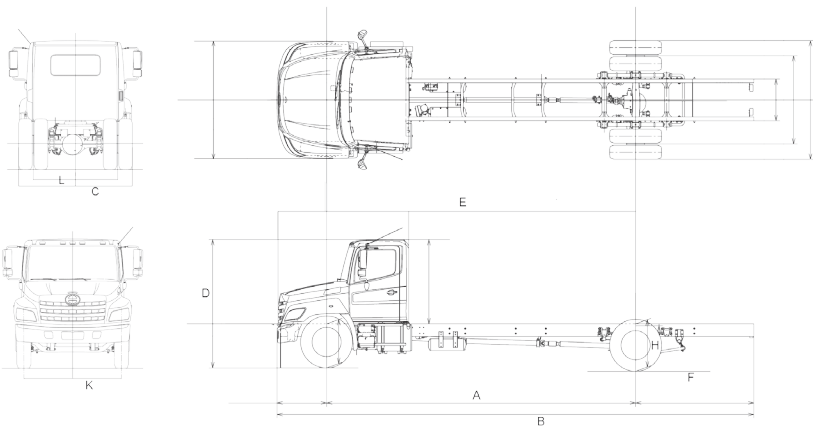

ENGINE

Model	J08E-VC
Type	Diesel 4-cycle, 6-cylinder in-line water-cooled, dry cylinder line
Combustion system	Direct injection type
Max. output (SAE Gross)	220HP at 2,500 rpm
Max. torque (SAE Gross)	520 lb.-ft. at 1,500 rpm
Bore and stroke	4.41 x 5.12 in.
Piston displacement	8 L
Fuel injection system	Common rail (HP-4)
Governor	Electronically controlled
Intake system	Turbocharged and intercooled
Air cleaner	Paper filter type (Donaldson)
Fan clutch	Bimetal thermostat sensor regulates fan speed
Glow plugs	Standard
Air compressor	Single cylinder, 10.3 cfm @ 1,250 rpm

POWERTRAIN AND PERFORMANCE

25,500 lbs. GVW		
Powertrain	STD	
Max. speed mph	85	
Startability (tan.θ) %	31.8	
Transmission	Model	Allison 2200 RDS
	Type	Six speed automatic
Ratios	1st	3.102
	2nd	1.811
	3rd	1.406
	4th	1.000
	5th	0.712
	6th	0.610
	Rev	4.492
Rear Axle Gear Ratios	4.11	
Tires (standard)	245/70R19.5	

* Max speed is limited by speed limiter.

HINOWATCH (service free of charge)

- 3 year unlimited roadside assistance
 - Lockout Service
 - Battery Jumpstart
 - Information
 - Warranty Towing (2 year coverage)

"HIGHEST IN CUSTOMER SATISFACTION WITH CONVENTIONAL MEDIUM DUTY ENGINES, THREE YEARS IN A ROW."
AND "HIGHEST IN CUSTOMER SATISFACTION WITH CONVENTIONAL MEDIUM DUTY TRUCKS."

1. Hino received the highest numerical score among conventional medium duty engines and transmissions in the proprietary J.D. Power and Associates 2008-2010 Medium Duty Truck Engine and Transmission Customer Satisfaction Study™. Study based on responses from 1,255 responses measuring 5 manufacturers. Survey was of primary maintainers and owner operators and measures opinions of primary maintainers of two-year-old (by model year) Medium Duty (Class 5, 6, and 7) trucks. Proprietary study results are based on experiences and perceptions of consumer surveyed in June-August 2010. Your experiences may vary. Visit jdpower.com.
 2. Hino received the highest numerical score among conventional medium duty trucks in the proprietary J.D. Power and Associates 2010 Medium Duty Truck Engine and Transmission Customer Satisfaction Study™. Study based on responses from 1,258 responses measuring 8 manufacturers. Survey was of primary maintainers and owner operators and measures opinions of primary maintainers of their new Medium Duty (Class 5, 6, and 7) trucks (2009 model year). Proprietary study results are based on experiences and perceptions of consumer surveyed in June-August 2010. Your experiences may vary. Visit jdpower.com.



WWW.HINO.COM



WEIGHT CAPACITIES

Front axle	lbs.	8,000
Rear axle	lbs.	17,500
Front spring	lbs.	8,000
Rear spring	lbs.	19,000

LIQUID CAPACITIES

Fuel tank	gal.	52
Cooling system	gal.	6.6: Allison 2200 RDS
Engine oil	qt.	16.2
DEF tank	gal.	4.7

AXLE / SUSPENSION

Front axle	MFS-8 series reversed Elliot, "I" beam (oil lubricated type)
Front spring	Taper-leaf springs shock absorber
Rear axle	RS17-145 series, full-floating, single reduction, single-speed by hypoid gearings
Rear spring	Semi-elliptic leaf spring

FRAME

Ladder type		Straight C Channel
Width	in.	34
Yield strength	PSI	80,000
Resisting bending moment (one side)	in.-lbs.	1,031,900 (no reinforcement)

STEERING

Steering column	Tilt and telescopic with lock adjustability
Steering system	TRW recirculating ball, with hydraulic booster, integral type

WHEELS / TIRES

6 Wheels	19.5 x 6.75 8-stud disc.
Wheel style	Steel, powder coated
6 Tires	245/70R19.5(G)
Tire pattern	Fr-rib Rr-lug type

BRAKES

Service brake	Hydraulic system with disc brake for front and rear wheels with automatic adjustment
Disc diameter x pad area (in. ²) x thickness (in.)	Front: 15.375 x 18.96 x 0.74 Rear: 15.375 x 18.96 x 0.74
Control	Hydraulic dual circuit with Antilock Brake System (ABS)
Parking brake	Mechanical, internal expanding acting on differential
Parking brake Drum diameter (in.)	12: Bosch
Exhaust brake	Electric-pneumatic with valve in exhaust pipe

CHASSIS EQUIPMENT

Radiator grille	Chrome
Fuel tank	Aluminum
Fuel pre-filter	Heated pre-filter (dust) and sedimentor (water)
Reflectors	Two rear, two front side
Tow hook	One at front
Air dryer	Nabtesco, heated
Air tank	34L

CAB EQUIPMENT

Air conditioning	Standard
Cab construction	All steel welded
Cigarette lighter	Equipped
Coat hook	One (rear panel)
Cruise control	Standard
Cup holders	Standard
Door pockets	Two
Driver's seat	2-way adjustable seat with arm rest and air suspension, covered with vinyl
Heater/Defroster	18,357 BTU/h
Mirrors	Four, 1-flat and 1-convex at each side
Overhead consoles	Two
Passenger's seat	Bench type, covered with vinyl
Seat belts	3-point type (driver and passenger), one 2-point type (center)
Seating capacity	Three
Speakers	Two
Sun visors	Two
Ventilator	Electric forced air
Windshield	Laminated
Windshield wipers	Dual electric, 2-speed/intermittent

DASH INSTRUMENTATION

Meters and gauges ft. lb. system
Speedometer-mph (km/h)
Odometer (mile)
Fuel gauge / DEF gauge
Coolant temperature gauge
Engine tachometer
Warning and pilot lamps and buzzers/audio
Oil pressure warning lamp and buzzer
Brake pressure warning lamp and buzzer
Coolant level warning lamp and buzzer
Battery charging warning lamp
High beam indicator lamp
Turn signal pilot lamp
Parking brake warning lamp
Engine control system warning lamp
ABS warning lamp
DEF quantity and quality audio
Driver Information Display (multilingual)
Instant and trip fuel consumption
DPR monitor
Maintenance
Engine/vehicle diagnostics

ELECTRICAL EQUIPMENT

Batteries	Two, parallel connection, each 12V
Capacity	1200 CCA
Alternator	12 V, 130 A, brush Delco
Starter	12 V, 4.0 kW Denso
Stereo	AM/FM radio with CD
Headlamps	Daytime running
Back-up lamps	
Dome lamp	
Electric horn (dual)	
Front side marker lamps	
Side-flasher lamp	
Stop/Tail lamps	
Trucklite LED marker lamps (front)	

CAB CONFIGURATION OPTIONS

Extended cab	30" cab extension, available with full width bench seat or 26" day bunk
--------------	-------------------------------------------------------------------------

OPTIONAL EQUIPMENT

Air horn
Air ride suspension - Hendrickson
Air ride suspension dump valve - Electric
Alternator - 12 V, 135 A, brushless Delco
Anti-Siphon device insert in fuel tank
Back-up aid alarm
Battery - Absorbed glass mat 31 configuration, 1850 CCA
Battery - Three parallel connection each 12 V (GR27x3)
Battery - Two or three parallel connection each 12 V (GR31 type)
Bumper, front - Black and 4 inch extension (available 3 piece)
Bumper, front - White and 4 inch extension (available 3 piece)
Bumper, front - White 3 piece (available with 1 or 2 tow hooks)
Bumper, front - Chrome and 4 inch extension
Bumper, front - Chrome (available with 1 or 2 tow hooks)
Cab paint, exterior - Black or red (factory)
Cab paint, exterior - Additional options available upon request
Cold weather package <ul style="list-style-type: none"> - Power Heated mirrors (available in chrome) - Engine block heater
Engine block heater
Engine idle shutdown
Exhaust system - Vertical stack type
Fuel tank - Dual 52 gal
Fuel tank - Single 95 gal.
Keyed alike - Matching key codes
Mirrors, fender - Chrome (both sides or passenger only)
Mirrors, outside rearview - Chrome
Mirrors, power heated (available in Chrome)
Power windows and power door locks (available with keyless entry)
Seats - Fabric with reclining single person passenger seat
Seats - Vinyl with reclining single person passenger seat
Seats - Fabric with two person bench seat
Sears seat - Vinyl black (upgrade driver seat only or with passenger seat upgrade)
Sears seat - Fabric black/silver (upgrade driver seat only or with passenger seat upgrade)
Shock absorbers, rear
Stabilizer, rear (leaf suspension only)
Synthetic fluids - Auto transmission and rear differential
Tire pattern - Rib on rear
Wheels - Alcoa polished aluminum
Wheels - Powder coated gray

NOTES

All specifications of the products are with normal manufacturing allowances and tolerances. Hino Motors Sales U.S.A., Inc. reserves the right to alter specifications at any time without previous notice. Some optional items of equipment may require extra time due to the need for their adaption on the product line.