

HINO 238

4 x 2 CONVENTIONAL

GVW: 23,000 lbs.

BBC: 108"

Engine Model: J08E-TV (Turbo Intercooled)

2009 SPECIFICATIONS

DIMENSIONS (On standard specification)							
Wheelbase/Code	A in.	175.0/J	187.0/L	205.0/M	217.0/P	235.0/R	253.0/T
Overall length	B in.	278.6	302.6	320.6	354.6	372.6	390.6
Overall width	C in.	95.7	95.7	95.7	95.7	95.7	95.7
Overall height	D in.	106.1	106.1	106.1	106.1	106.1	106.1
Cab to axle	E in.	107.6	119.6	137.6	149.6	167.6	185.6
Rear overhang	F in.	63.0	75.0	75.0	97.0	97.0	97.0
Frame height at:	G in.	36.2	36.2	36.2	36.2	36.2	36.2
	H in.	39.0	39.0	39.0	39.0	39.0	39.0
Road clearance (at diff. axle)	J in.	10.6	10.6	10.6	10.6	10.6	10.6
Tread:	K in.	78.0	78.0	78.0	78.0	78.0	78.0
	L in.	72.0	72.0	72.0	72.0	72.0	72.0
Turning radius:	ft.	47.8	50.8	55.2	58.2	62.6	67.0
	ft.	51.4	54.4	58.6	61.6	66.0	70.4

CHASSIS WEIGHTS (On standard specification)								
AT	Total weight	lb.	9,310	9,380	9,490	9,600	9,680	9,710
	Front axle	lb.	5,880	5,940	6,040	6,050	6,140	6,185
	Rear axle	lb.	3,430	3,440	3,450	3,550	3,540	3,525

ENGINE	
Model	HINO J08E-TV
Type	Diesel 4-cy., 6-cyl. in-line, water-cooled
Combustion system	Direct injection type
Max. output (SAE Gross)	220HP at 2,500 rpm
Max. torque (SAE Gross)	520 lb.-ft. at 1,500 rpm
Bore and stroke	4.41 x 5.12 in.
Piston displacement	7.680L
Fuel injection pump	Radial plunger pump (HP-4)
Governor	Electronically controlled
Intake system	Turbocharged and intercooled
Air cleaner	Paper filter type (Donaldson)
Fan clutch	Bimetal thermostat sensor regulates fan speed
Glow plugs	Standard
Air compressor	Single cylinder, 6.8 cfm @ 1,250 rpm

POWERTRAIN AND PERFORMANCE		
23,000 lbs. GVW		
Powertrain	<input type="checkbox"/> STD.	<input type="checkbox"/> OPT.
Max. speed mph	79*	78*
Startability (tan.θ) %	38.6	38.8
Transmission Model	Allison 2200HS/RDS	
Type	Six-speed automatic	
Ratios	1st.	3.102
	2nd.	1.811
	3rd.	1.406
	4th.	1.000
	5th.	0.712
	6th.	0.610
	Rev.	4.492
Rear axle gear ratios	5.290	5.130
Tire is combined with ratio	10R22.5-14	255/80R22.5

(* Maximum speed is limited with speed limiter)

ROADSIDE ASSISTANCE	
HinoWatch (service free of charge)	3-year unlimited roadside assistance <ul style="list-style-type: none"> • Lockout • Out of Fuel • Battery Jumpstart • Information • Warranty Towing

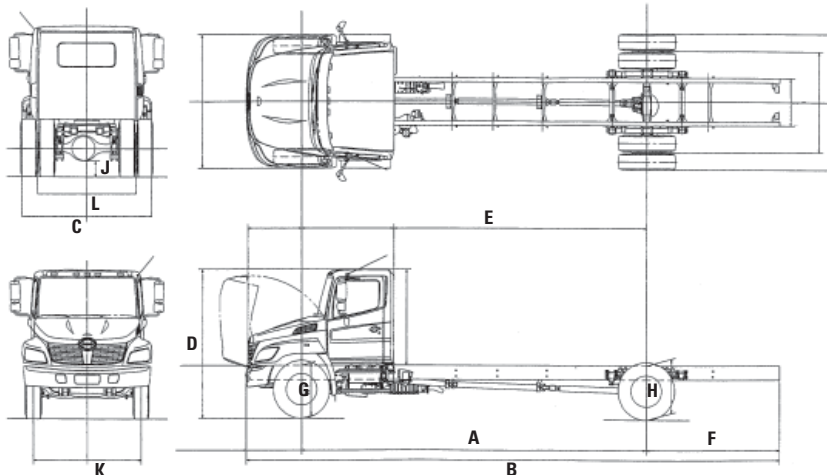

WEIGHT CAPACITIES		
Front axle	lbs.	8,000
Rear axle	lbs.	17,500
Front spring	lbs.	8,000
Rear spring	lbs.	19,000

LIQUID CAPACITIES		
Fuel tank	gal.	52
Cooling system	gal.	6.08
Engine oil	qt.	16.15

AXLE/SUSPENSION	
Front axle	MFS-8 series reversed Elliot, "I" beam with oil lubricated type
Front spring	Taper-leaf springs shock absorbers
Rear axle	RS17-145 series Full-floating, single reduction Single-speed by hypoid gearings
Rear spring	Semi-elliptic main and auxiliary helper-leaf spring

FRAME		
Ladder type		Straight C Channel
Width	in.	34
Yield strength	PSI	80,000
Resisting bending moment (one side)	in.-lbs.	1,031,900 no reinforcement

STEERING	
Steering column	Tilt and telescopic with lock adjustability
Steering system	TRW recirculating ball, with hydraulic booster, integral type

WHEELS/TIRES	
6 Wheels	22.2 x 8.25 10-stud disc.
Wheel style	Steel, powder coated
6 Tires	10R22.5(G)
Tire brand and pattern	Bridgestone Fr-rib/Rr-lug type

BRAKES	
Service brake	Hydraulic system with disc brake for front and rear wheels, with automatic adjustment
Disc diameter x pad area (in ²) x thickness (in.)	Front; 15.375 x 18.96 x 0.74 Rear; 15.375 x 18.96 x 0.74
Control	Hydraulic dual circuit with Antilock Brake System(ABS)
Parking brake	Mechanical, internal expanding acting on transmission output shaft
Drum diameter (in.)	9 : Bosch
Exhaust brake	Without combination lever

CHASSIS EQUIPMENT	
Radiator grille	Chrome
Fuel tank	Aluminum
Fuel pre-filter	Heated pre-filter (dust) and sedimenter (water)
Reflectors	Two rear, two front side
Tow hook	One at front
Air dryer	NABCO, heated
Air tank	49L

CAB EQUIPMENT	
Air conditioning	Equipped
Cab construction	All steel welded
Seating	Three
Driver's seat	Adjustable reclining, covered with vinyl with coil suspension
Passenger's seat	Bench type, covered with vinyl
Seat belts	3-point type (driver and passenger), one 2-point type (center)
Heater/Defroster	18,357 BTU/h
Mirrors, outside rearview	Four, 1-flat and 1-convex at each side
Sun visors	Two
Over-head consoles	Two
Ventilator	Electric forced air
Windshield	Laminated
Windshield wipers	Dual electric, 2-speed and intermittent
Cup holders	Two at center cluster
Cigarette lighter	Equipped
Speakers	Two for front
Coat hook	One (rear panel)
Door pockets	Two
Cruise control	Standard

DASH INSTRUMENTATION	
Meters and gauges	ft. lb. system
	Speedometer-mph (km/h)
	Odometer (mile)
	Fuel gauge
	Coolant temperature gauge
	Engine tachometer
Warning and pilot lamps and buzzers	
	Oil pressure warning lamp and buzzer
	Brake pressure warning lamp and buzzer
	Coolant level warning lamp and buzzer
	Battery charging warning lamp
	High beam indicator lamp
	Turn signal pilot lamp
	Parking brake warning lamp
	Engine control system warning lamp
	ABS warning lamp
Driver Information Display	
	Instant and trip fuel consumption
	DPR monitor
	Maintenance schedule
	Engine/vehicle diagnostics

ELECTRICAL EQUIPMENT	
Batteries	Two, parallel connection, each 12V
Capacity	1200 CCA
Alternator	12 V, 100 A, brush Delco
Starter	12 V, 4.8 kW Denso
Car audio	AM/FM radio with CD
Headlamps	Daylight running - integrated with turn signal and hazard lamps
Identification lamps (front)	
Stop/Tail lamps	
Back-up lamps	
Side-flasher lamp	
Dome lamp	
Front side marker lamps	
Trucklite LED cab marker lamps (front)	
Electric horn (dual)	

CAB CONFIGURATION OPTIONS	
Extended cab	30" cab extension, available with full-width bench seat or 26" day bunk

OPTIONAL EQUIPMENT	
Air horn	
Air ride suspension - Hendrickson (N/A on G, J wheelbases)	
Air ride suspension dump valve - Electric	
Alternator - 12 V, 105 A, brushless	
Battery - Three parallel connection each 12 V (GR27x3)	
Battery - Two or three parallel connection each 12 V (GR31 type)	
Battery - Absorbed glass mat (AGM) 31 Configuration	
Bumper, front - Black and 4 inch extension (available 3 piece)	
Bumper, front - White and 4 inch extension (available 3 piece)	
Bumper, front - White 3 piece (available with one or two tow hooks)	
Bumper, front - Chrome and 4 inch extension	
Bumper, front - Chrome (available with one or two tow hooks)	
Cab paint, exterior - Black	
Cab paint, exterior - Red	
Cold weather package	
- Heated mirrors (available in chrome)	
- Engine block heater	
Engine block heater	
Exhaust system - Vertical stack type (N/A with 95 gal. fuel tank)	
Fuel tank - Dual 52 gal. (N/A on G wheelbase)	
Fuel tank - Single 95 gal.	
Mirrors, outside rearview - Heated with marker light	
Mirrors, outside rearview - Chrome, heated with marker light	
Mirrors, outside rearview - Chrome	
Power windows and power door locks	
Seat - Driver's seat with air suspension	
Seats - Vinyl with reclining single person passenger seat	
Seats - Fabric with reclining single person passenger seat	
Seats - Fabric with two person bench seat	
Seating capacity - Two or three person	
Shock absorbers, rear	
Stabilizer, rear	
Stabilizer, rear - With shock absorbers	
Synthetic fluids - Auto transmission and rear differential	
Tire pattern - Rib on rear	
Tire size - 255/80R22.5-14(G) Michelin	
Tow hooks - Two at front	
Transmission, automatic - Allison 2200 RDS with PTO drive gear (rear axle ratio 5.13)	
Wheels - Alcoa polished aluminum (inner rear wheels are steel)	
Engine idle throttle knob - Removed	
Exhaust brake - Disengage	

NOTE:
 All specifications of the products are with normal manufacturing allowances and tolerances. HINO MOTORS SALES U.S.A., INC. reserves the right to alter specifications at any time without previous notice. Some optional items of equipment may require extra time due to the need for their adaptation on the product line.